

MK06 Bluetooth Module

(MK06A、MK06B)

Datasheet

Contents

1. Product Instruction	1
1.1 Model Classification	1
1.2 Key Features	2
1.3 Applications	3
1.4 Product Specifications	4
2. Block Diagram	6
3. Mechanical specifications	7
3.1 Module Mechanical Dimensions	7
3.2 Recommended PCB land pads	8
4. Pin Assignment	9
5. Mounting Suggestion	11
6. Cautions	13
6.1 Reflow Soldering	13
6.2 Usage Condition Notes	14
6.3 Storage Notes	15
Revision History	15

1. Product Instruction

MK06 series is a powerful, highly flexible, ultra low power **Bluetooth® 5.1** module based on **Nordic® Semiconductor nRF52811 SoC** solution, which has a 32bit Arm® Cortex™-M4 CPU with floating point unit running at 64MHz.

MK06 is capable of the latest and greatest features of Bluetooth® 5.1, the most prominent being Direction Finding¹, taking Bluetooth positioning to new heights.

MK06 supports an extensive range of wireless protocols. It supports BLE® (Bluetooth Low Energy) , and is capable of Bluetooth® Direction Finding in addition Long Range and 2 Mbps. Thread, and 2.4 GHz proprietary protocols are also supported.

1.1 Model Classification

There are two models of **MK06** series Bluetooth module — **MK06A and MK06B**. The two models both have a small size of 21 x 13.8 x 2.3mm with all 30 GPIOs of nRF52811QFAA (QFN48 package).

The difference between MK06A and MK06B is the antenna design.

MK06A integrates a high-performance PCB antenna.

MK06B uses a u.FL connector and requires an external 2.4Ghz antenna.

MOKO development team can assist you in selecting high-performance antennas that suit your needs.

1. Direction Finding enables positioning solutions to not only rely on received signal strength indicator (RSSI), but also the actual direction of a signal. This improves accuracy significantly and opens new possibilities for applications in this segment. There are two types of methods for determining direction, angle of arrival (AoA), where the direction of the received signal is calculated, and angle of departure (AoD), where the direction of the transmitted signal is calculated.

1.2 Key Features

- Bluetooth 5
 - Direction Finding
 - 2Mbps
 - CSA#2
 - Advertising Extensions
 - Long Range
- IEEE 802.15.4 radio support
 - Thread
 - Zigbee
- Supported data rates
 - Bluetooth®: 2Mbps, 1Mbps, 500kbps, and 125kbps
 - IEEE 802.15.4-2006: 250 kbps
 - Proprietary 2.4 GHz: 2 Mbps, 1 Mbps
- Wide supply voltage range: 1.7 V to 3.6 V
- 192kB Flash and 24kB RAM
- Full set of digital interfaces including: SPI, TWI, UART, PDM, PWM, QDEC
- 12-bit, 200ksps ADC
- 128-bit AES ECB/CCM/AAR co-processor
- Individual power management for all peripherals
- On-chip DC/DC buck converter
- Dimension: 21.0 x 13.8 x 2.3mm (with shield)
- 30 GPIOs

1.3 Applications

- **IoT**
 - Home automation
 - Sensor networks
 - Building automation
 - Industrial automation
- **Personal area networks**
 - Health/fitness sensor and monitor devices
 - Medical devices
 - Key fobs and wrist watches
- **Interactive entertainment devices**
 - Remote controls
 - Gaming controllers
 - VR/AR
- **Enterprise lighting**
 - Industrial
 - Commercial
 - Retail
- **Beacons**
- **Computer peripherals and I/O devices**
 - Mouse
 - Keyboard
 - Mobile HID

1.4 Product Specifications

Detail	Description
Bluetooth	
Feature	Bluetooth® Low Energy Direction Finding 2M LE PHY 1M LE PHY Coded LE PHY (Long Range) Advertising Extensions CSA #2
Security	AES-128
LE connections	Concurrent peripheral and broadcaster roles
Radio	
Frequency	2360MHz - 2500MHz
Modulations	GFSK at 1Mbps, 2Mbps, 250kbps (IEEE 802.15.4-2006) and long range (125kbps and 500kbps) data rates
Transmit power	+4 dBm maximum Configurable down to -40dBm
Receiver sensitivity	-104 dBm sensitivity in 125 kbps Bluetooth® low energy mode -100 dBm sensitivity in 500 kbps Bluetooth® low energy mode -97 dBm sensitivity in 1 Mbps Bluetooth® low energy mode -94 dBm sensitivity in 2 Mbps Bluetooth® low energy mode -101 dBm sensitivity in 250 kbps Thread mode -94 dBm sensitivity in 1 Mbps ANT mode -94 dBm sensitivity in 1 Mbps 2.4 GHz mode -91 dBm sensitivity in 2 Mbps 2.4 GHz mode
Antenna	MK06A - PCB trace antenna MK06B - External 2.4Ghz antenna
Advertising distance @1Mbps (Open area)	MK06A - More than 150 meters
Current consumption	
TX only (DCDC enabled, 3V) @ +4dBm / 0dBm / -4dBm/-20dBm/-40dBm	7mA / 4.6mA / 3.6mA / 2.5mA / 2.1mA
TX only @ +4dBm / 0dBm / -4dBm / -20dBm / -40dBm	15.4mA / 10.1mA / 7.8mA / 5.4mA / 4.3mA
RX only (DCDC enabled, 3V) @1Msps BLE	4.6mA
RX only @ 1Msps BLE	10.0mA
RX only (DCDC enabled, 3V) @2Msps BLE	5.2mA
RX only @ 2Msps BLE	11.2mA
System OFF mode(3V)	0.3uA
System OFF mode with full 24kB RAM retention(3V)	0.5uA
System ON mode with full 24 kB RAM retention, wake on RTC (3V)	1.5uA

MK06 Bluetooth Module

Datasheet

Detail	Description
System ON mode, no RAM retention, wake on RTC(3V)	1.4uA
Mechanical design	
Dimensions	Length: 21mm±0.2mm Width: 13.8mm±0.2mm Height: 2.3mm+0.1mm/-0.15mm
Package	34 Plated Half-hole pins
PCB material	FR-4
Impedance	50Ω
Hardware	
CPU	ARM® Cortex®-M4 32-bit processor with FPU, 64 MHz
Memory	192kB flash, 24 kB RAM
Interfaces	2x SPI master/slave with EasyDMA I ² C compatible 2-wire master/slave UART (CTS/RTS) with EasyDMA 4-channel pulse width modulator (PWM) unit with EasyDMA Digital microphone interface (PDM) Quadrature decoder (QDEC) 2x real-time counter (RTC) 3x 32-bit timer with counter mode 30 GPIOs 8x 12-bit, 200ksps ADC
Power supply	1.7V to 3.6V
Operating temperature range	-40 to 85 °C
Clock control	32.768 kHz +/-20 ppm crystal oscillator
Power regulator	DC/DC regulator setup
Certifications	
USA (FCC)	FCC part 15 modular certification 47 CFR Part 15, Subpart C FCC ID: 2AO94-MK06
Europe (CE)	EN 300 328 V2.2.2 3.2: Effective use of spectrum allocated EN 301 489-1 V2.2.3 3.1(b): Electromagnetic Compatibility EN 301 489-17 V3.2.4 EN 62368-1: 2014+A11:2017 3.1(a): Health and Safety of the user EN 62479: 2010
Canada (ISED)	Industry Canada RSS-247 and RSS-Gen certification IC: 26442-MK06
Japan (MIC)	Ministry of Internal Affairs and Communications (MIC) of Japan pursuant to the Radio Act of Japan
Australia/New Zealand (RCM)	AS/NZS 4268: 2017, Radio equipment and systems-short range devices

2. Block Diagram

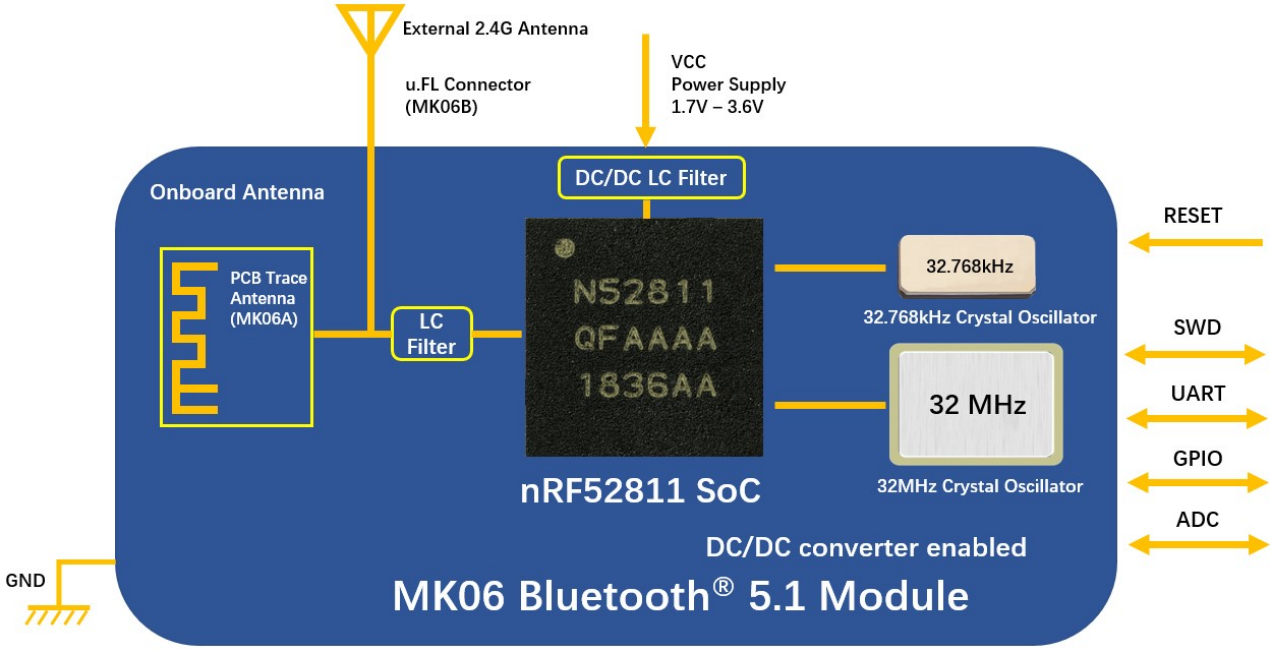

3. Mechanical specifications

3.1 Module Mechanical Dimensions

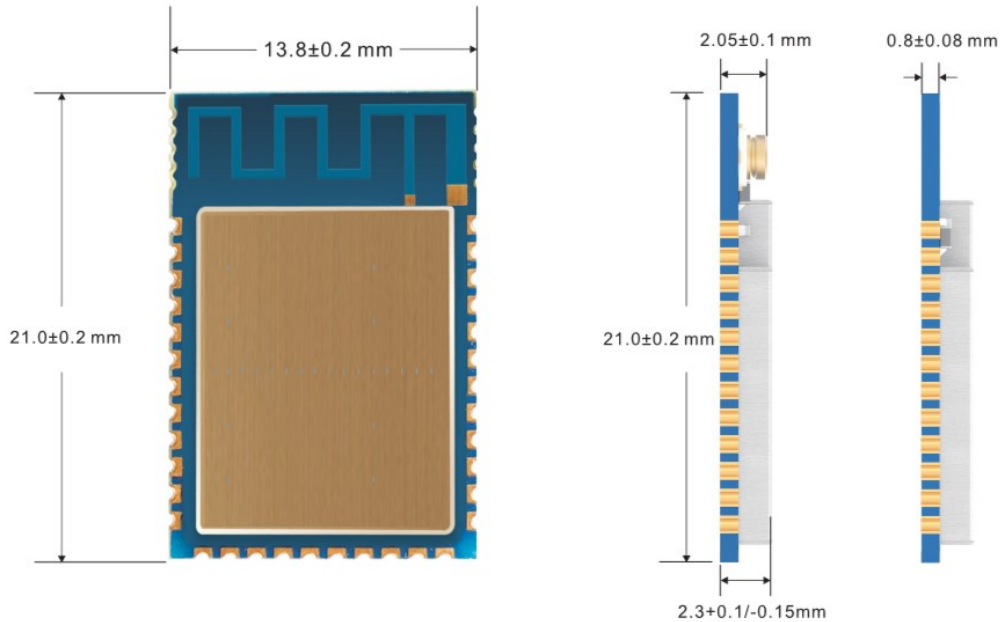

Symbol	Min.	Typ.	Max.
Length	-0.2mm	21mm	+0.2mm
Width	-0.2mm	13.8mm	+0.2mm
Height (PCB only)	-0.08mm	0.8mm	+0.08mm
Height (with shield)	-0.15mm	2.3mm	+0.1mm

3.2 Recommended PCB land pads

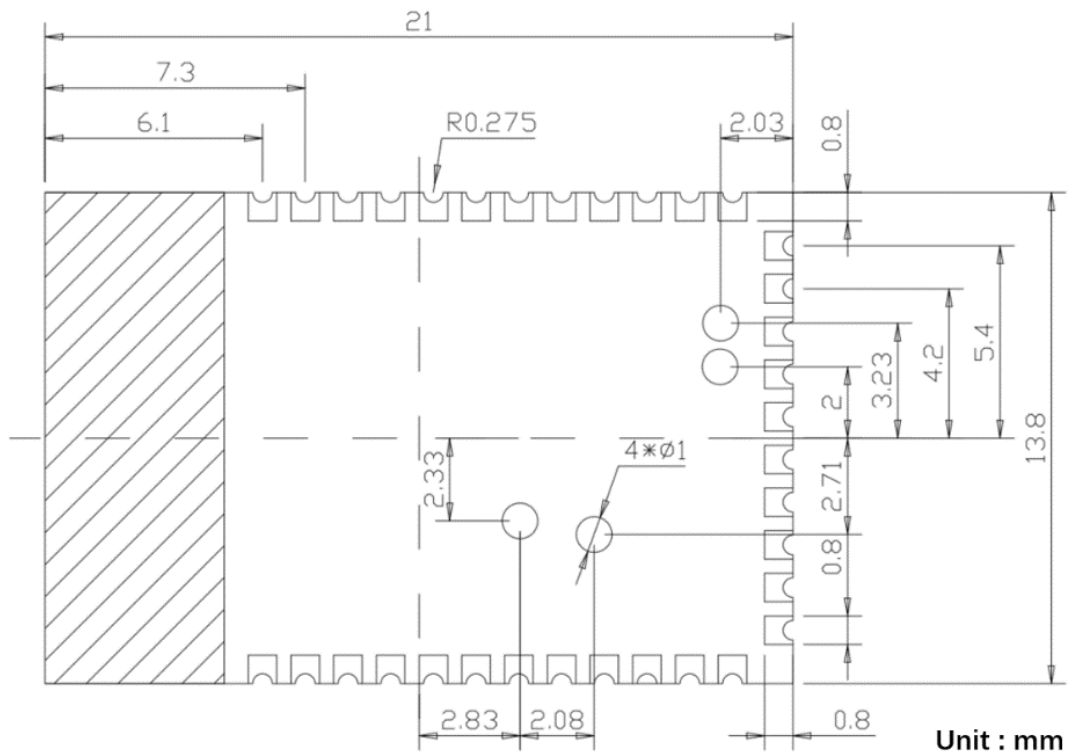

MK06 PCB land pads (TOP View)

Symbol	Typ.
Half-hole Pad (Bottom)	0.8mm x 0.8mm
LGA Round Pad	1mm (diameter)
Diameter of Half-hole	0.55mm

4. Pin Assignment

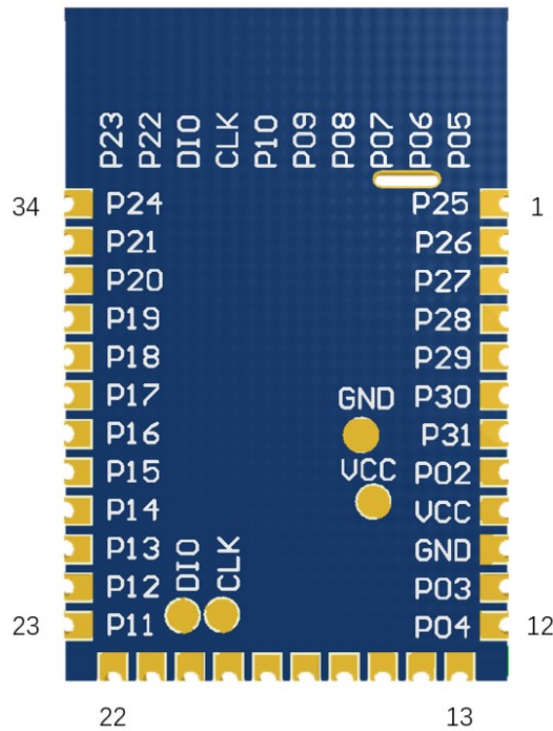

MK06 module pin diagram (Rear View)

Pin No.	Name	Type	Description
1	P25	Digital I/O	General purpose I/O
2	P26	Digital I/O	General purpose I/O
3	P27	Digital I/O	General purpose I/O
4	P28	Digital I/O	General purpose I/O
	AIN4	Analog input 4	SAADC/COMP/LPCOMP input
5	P29	Digital I/O	General purpose I/O
	AIN5	Analog input 5	SAADC/COMP/LPCOMP input
6	P30	Digital I/O	General purpose I/O
	AIN6	Analog input 6	SAADC/COMP/LPCOMP input
7	P31	Digital I/O	General purpose I/O
	AIN7	Analog input 7	SAADC/COMP/LPCOMP input
8	P02	Digital I/O	General purpose I/O
	AIN0	Analog input 0	SAADC/COMP/LPCOMP input
9	VCC	Power	Power Supply: 1.7V-3.6V
10	GND	Power	Ground
11	P03	Digital I/O	General purpose I/O
	AIN1	Analog input 1	SAADC/COMP/LPCOMP input
12	P04	Digital I/O	General purpose I/O
	AIN2	Analog input 2	SAADC/COMP/LPCOMP input

MK06 Bluetooth Module

Datasheet

Pin No.	Name	Type	Description
13	P05	Digital I/O	General purpose I/O
	AIN3	Analog input 3	SAADC/COMP/LPCOMP input
14	P06	Digital I/O	General purpose I/O
15	P07	Digital I/O	General purpose I/O
16	P08	Digital I/O	General purpose I/O
17	P09	Digital I/O	General purpose I/O
18	P10	Digital I/O	General purpose I/O
19	SWDCLK	Digital input	Serial wire debug clock input for debug and programming
20	SWDIO	Digital I/O	Serial wire debug I/O for debug and programming
21	P22	Digital I/O	General purpose I/O
22	P23	Digital I/O	General purpose I/O
23	P11	Digital I/O	General purpose I/O
24	P12	Digital I/O	General purpose I/O
25	P13	Digital I/O	General purpose I/O
26	P14	Digital I/O	General purpose I/O
27	P15	Digital I/O	General purpose I/O
28	P16	Digital I/O	General purpose I/O
29	P17	Digital I/O	General purpose I/O
30	P18	Digital I/O	General purpose I/O
31	P19	Digital I/O	General purpose I/O
32	P20	Digital I/O	General purpose I/O
33	P21	Digital I/O	General purpose I/O
	RESET		Configurable as pin reset
34	P24	Digital I/O	General purpose I/O

Note: Please refer to [Nordic nRF52811 Product Specifications](#) for detailed descriptions and features supported about the Pin assignments.

5. Mounting Suggestion

You can refer to the following references for the mounting design of the module with on-board antenna (MK06A with PCB antenna).

For external antenna modules (MK06B needs to connect an external antenna to the u.FL connector), you need to refer to the external antenna design requirements.

Recommended module mounting example:

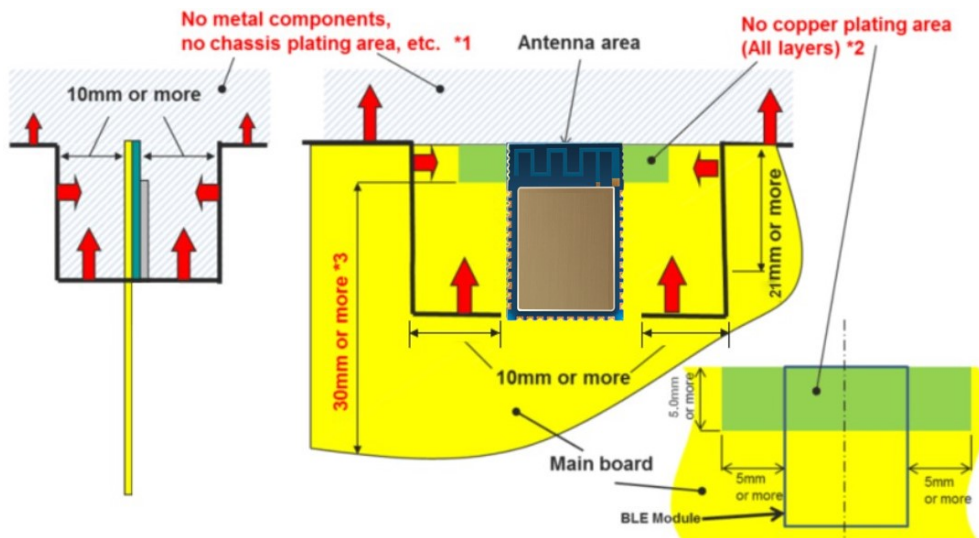

- Please do not place any metal components in blue shaded space(*1), such as signal line and metal chassis as possible except for main board while mounting the components in *1 space on the main board is allowed except for no copper plating area(*2).
- (*2)This area is routing prohibited area on the main board. Please do not place copper on any layer.
- (*3)Characteristics may deteriorate when GND pattern length is less than 30mm. It should be 30 mm or more as possible.
- For the best Bluetooth range performance, the antenna area of module shall extend 3 mm outside the edge of main board, or 3 mm outside the edge of a ground plane. Ground plane shall be at least 5 mm from the edge of the antenna area of module.
- All module GND pins MUST be connected to main board GND. Place GND vias close to module GND pads as possible. Unused PCB area on surface layer can flooded with copper but place GND vias regularly to connect copper flood to inner GND plane. If GND flood copper underside the module then connect with GND vias to inner GND plane.
- Even when above mentioned condition is satisfied, communication performance may be significantly deteriorated depending on the structure of the product. Bluetooth range performance is degraded if a module is placed in the middle of the main board.
- For main board layout:
 - Avoid running any signal line below module whenever possible.
 - No ground plane below antenna.
 - If possible, cut-off the portion of main board below antenna.

MK06 Bluetooth Module

Datasheet

Other module mounting examples:

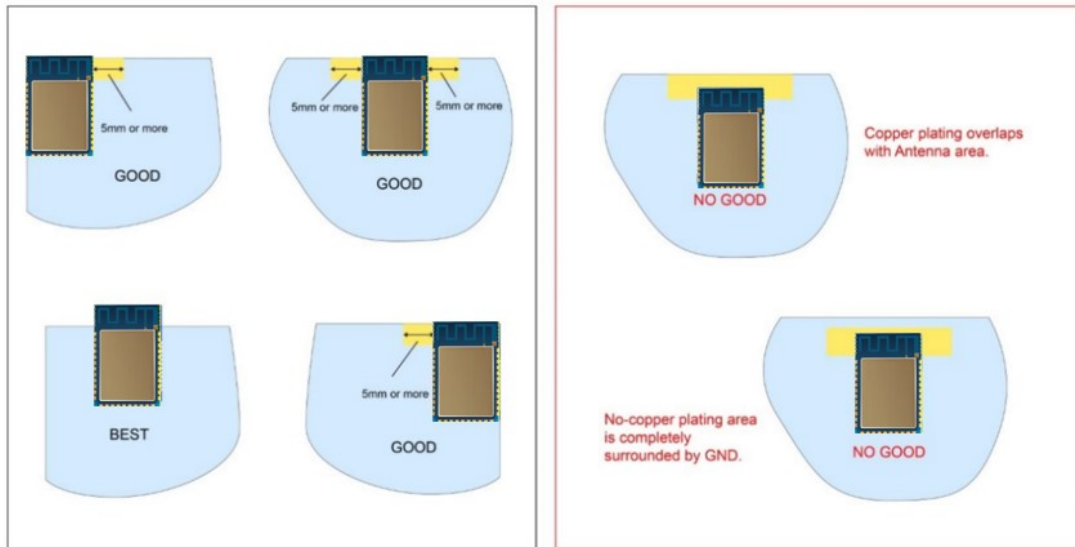

Placement of resin or plastic parts:

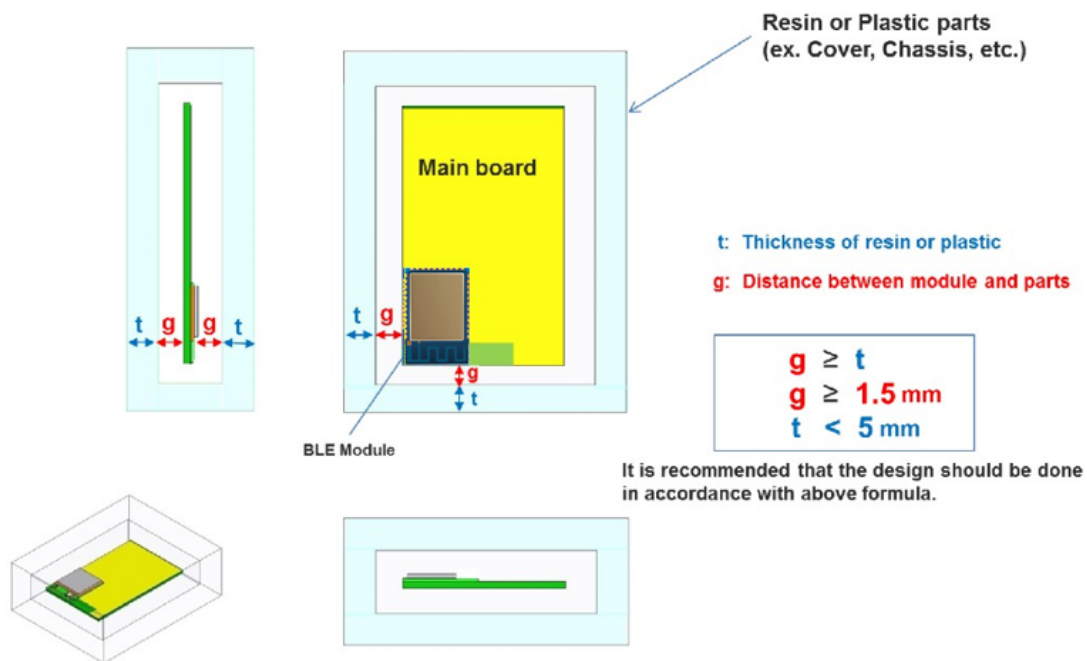

Please do not apply molding over the antenna area of BLE module.

Placement of metal parts

- Minimum safe distance for metal parts without seriously compromising the antenna (tuning) is 40 mm top/bottom and 30 mm left or right.
- Metal close to the module antenna (bottom, top, left, right, any direction) will have degradation on the antenna performance. The amount of that degradation is entirely system dependent, meaning you will need to perform some testing with your host application.
- Any metal closer than 20 mm will begin to significantly degrade performance (S11, gain, radiation efficiency).
- It is best that you test the range with a mock-up (or actual prototype) of the product to assess effects of enclosure height (and materials, whether metal or plastic).

6. Cautions

6.1 Reflow Soldering

Reflow soldering is a vitally important step in the SMT process. The temperature curve associated with the reflow is an essential parameter to control to ensure the correct connection of parts. The parameters of certain components will also directly impact the temperature curve selected for this step in the process.

Temperature-Time Profile for Reflow Soldering:

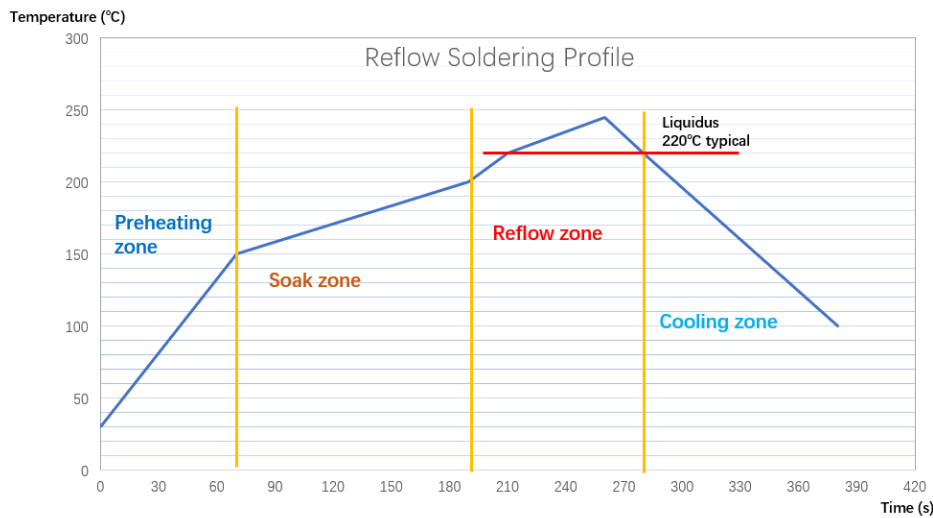

- The standard reflow profile has four zones: ①preheat, ②soak, ③reflow, ④cooling. The profile describes the ideal temperature curve of the top layer of the PCB.
- During reflow, modules should not be above 260°C and not for more than 30 seconds.

Specification	Value
Temperature Increase Rate	<2.5°C/s
Temperature Decrease Rate	Free air cooling
Preheat Temperature	0-150°C
Preheat Period (Typical)	40-90s
Soak Temp Increase Rate	0.4-1°C/s
Soak Temperature	150-200°C
Soak Period	60-120s
Liquidus Temperature (SAC305)	220°C
Time Above Liquidous	45-90s
Reflow Temperature	230-250°C
Absolute Peak Temperature	260°C

MK06 Bluetooth Module

Datasheet

Example of MOKO SMT reflow soldering:

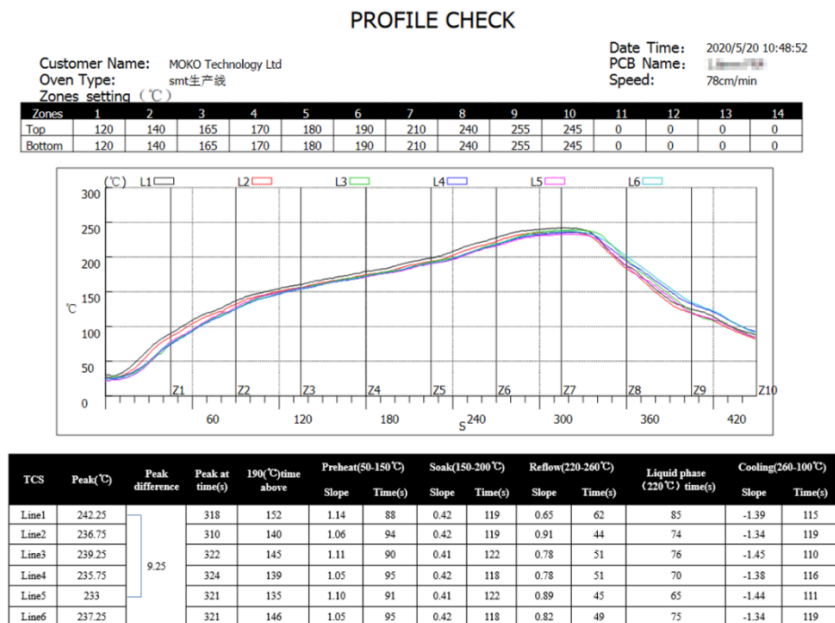

Note: The module is LGA package. Please be careful of the amount of solder paste. The module may be lifted due to excess solder.

6.2 Usage Condition Notes

- Follow the conditions written in this specification, especially the recommended condition ratings about the power supply applied to this product.
- The supply voltage has to be free of AC ripple voltage (for example from a battery or a low noise regulator output). For noisy supply voltages, provide a decoupling circuit (for example a ferrite in series connection and a bypass capacitor to ground of at least 47uF directly at the module).
- Take measures to protect the unit against static electricity. If pulses or other transient loads (a large load applied in a short time) are applied to the products, check and evaluate their operation before assembly on the final products.
- The supply voltage should not be exceedingly high or reversed. It should not carry noise and/or spikes.
- This product away from other high frequency circuits.
- Keep this product away from heat. Heat is the major cause of decreasing the life of these products.
- Avoid assembly and use of the target equipment in conditions where the products' temperature may exceed the maximum tolerance.
- This product should not be mechanically stressed when installed.
- Do not use dropped products.
- Do not touch, damage or soil the pins.
- Pressing on parts of the metal shield or fastening objects to the metal shield will cause damage.

6.3 Storage Notes

- The module should not be stressed mechanically during storage.
- Do not store these products in the following conditions or the performance characteristics of the product, such as RF performance will be adversely affected:
 - Storage in salty air or in an environment with a high concentration of corrosive gas.
 - Storage in direct sunlight
 - Storage in an environment where the temperature may be outside the range specified.
 - Storage of the products for more than one year after the date of delivery storage period.
- Keep this product away from water, poisonous gas and corrosive gas.
- This product should not be stressed or shocked when transported.

Revision History

Revision	Description of changes	Approved	Revision Date
V1.0	Initial Release	Kevin	2020.09.04
V1.1	Updated Section 1.4	Victor	2020.10.15

MK06 Bluetooth Module

Datasheet

The contents of this datasheet are subject to change without prior notice for further improvement. MOKO team reserves all the rights for the final explanation.

Please contact MOKO sales team or visit <https://www.mokosmart.com> to get more related information if needed.

MOKO TECHNOLOGY LTD.

 4F,Buidling2, Guanghui Technology Park,
MinQing Rd, Longhua, Shenzhen, Guangdong, China

 Tel:86-755-23573370-829

 Support_BLE@mokotechnology.com

 <https://www.mokosmart.com>

